

Docking equipment

Crawford DE6090DI

ASSA ABLOY

ASSA ABLOY Entrance Systems

The global leader in
door opening solutions



Exclusive and innovative guide- and traffic lights for docking

The Crawford DE6090DI Dock-IN from ASSA ABLOY Entrance Systems is the world first combined solution with parking guide- and traffic lights in one system. With Crawford DE6090DI Dock-IN you will have a safe and secure docking with help of white guiding lights and red traffic lights.

The white guide lights gives the driver a visual target to align the truck with the docking bay to make approaching the dock easy and safe. Truck drivers look downwards to the rear tires and unlike conventional traffic light systems the red signal of the Crawford DE6090DI Dock-IN is in the optimal position below the door. Only when the truck is in place the control box functions are released; the interlocking function "truck in place" helps the operator to save energy and to control the complete loading process.

With the guide- and traffic lights, there is no need to paint or repaint the guiding lines on the asphalt. There is also no need for conventional parking guides of steel pipes, which are an obstacle on the yard and also when removing snow.

Thanks to modern LED technology, Crawford DE6090DI Dock-IN has a low energy consumption and a long lifetime.

Benefits

- The Crawford DE6090DI Dock-IN offer much more visual aid than white stripes painted on the asphalt.
- No need to paint and repaint the lines on the asphalt and lines are not hidden by snow.
- No need for conventional parking guides of steel pipes which are an obstacle on the yard and give problems with removal of snow.
- Very low energy consumption and long life time because of modern LED technology.
- Reduces the risk of damage to the docking facility and the trucks.
- Sustainable Safety Solution.
- Green Footprint Solution.
- As a bonus, you get a nicely designed basic lighting in front of the leveller when it is dark outside, which gives the building a nice profile.

Technical Data

Life time	5 years when powered-up at 24H/day
Power of LED's	2,4 W
Operating voltage	24 VDC
Operating temperature	-20°C to +55 °C
Operating humidity	0-80% rel., not condensing
Degree of protection	IP 66

1) Truck reversing to the dock

Function description

- White LED's left and right are ON
- Additional LED on driver's side OFF
- Control Box is blocked without any visible sign on the Control Box

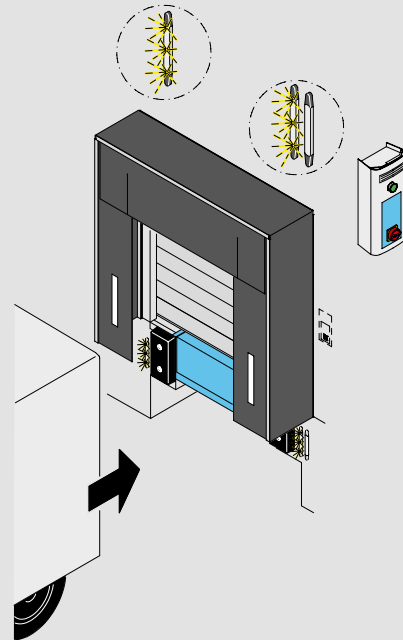

2) Truck arrives at dock / Truck in place

Function description

- Sensor detects the truck
- White LED's turn OFF
- Red LED on driver's side turns ON
- Control Box is released and green LED lamp on the box turns ON

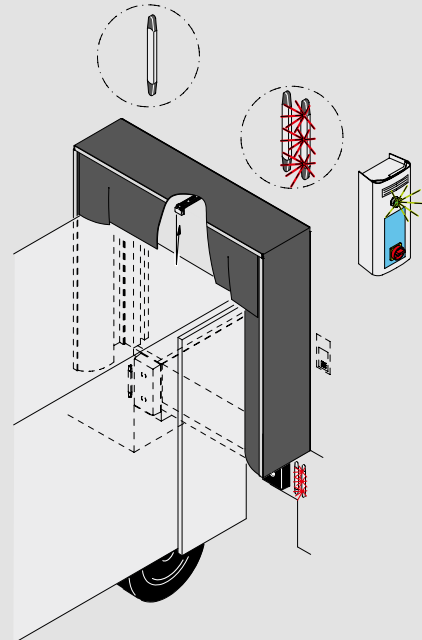

3) Truck drives off

Function description

- Sensor detects truck leaving
- White LED's turn ON
- Red LED on driver's side turns OFF
- Control Box is blocked and green LED lamp on the box turns OFF

